

The information in this document is subject to change without notice and should not be construed as a commitment by ABB. ABB assumes no responsibility for any errors that may appear in this document.

Except as may be expressly stated anywhere in this document, nothing herein shall be construed as any kind of guarantee or warranty by ABB for losses, damages to persons or property, fitness for a specific purpose or the like.

In no event shall ABB be liable for incidental or consequential damages arising from use of this document.

This document and parts thereof must not be reproduced or copied without ABB's written permission, and contents thereof must not be imparted to a third party nor be used for any unauthorized purpose. Contravention will be prosecuted.

Additional copies of this document may be obtained from ABB at its then current charge.

© Copyright 2017 ABB ALL right reserved.

ABB AB

SE-721 68 Västerås
Sweden

Latest revision: ECO 93258 WI 157932 Pg 11(3 to 4): Fuse F1 & F2 added. Pg 11(4): Description "Lubrication pump" was "Trabon".			Lab/Office: RMRO/PRIM	ROBOT CARRIER IRBT 4004/6004/7004 COPYRIGHT PAGE	Status: APPROVED	Plant: = Location: + Sublocation: +
Prepared by, date: EM, 2017-09-20	Approved by, date: JN, 2017-09-29		Document no. 3HAC043574-001		Rev. Ind 06	Page 1 Next 2 Total 23

We reserve all rights in this document and in the information contained therein. Reproduction, use or disclosure to third parties without express authority is strictly forbidden. © Copyright 2003 ABB

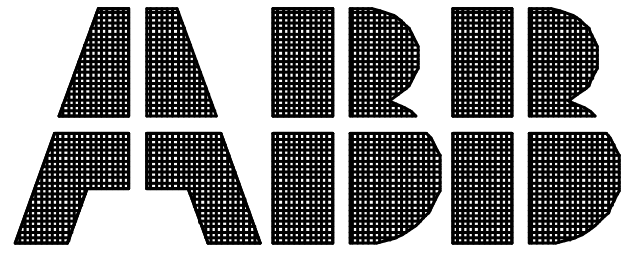

Description : ROBOT CARRIER IRBT 4004/6004/7004
 Drawing number : 3HAC043574-001
 Drawing version : 06
 Date : 2017-09-29

Customer :
 Year of construction :

Drawn by : RMRO/PRIM
 Number of pages : 23

We reserve all rights in this document and in the information contained therein. Reproduction, use or disclosure to third parties without express authority is strictly forbidden. © Copyright 2003 ABB

Latest revision:
 ECO 93258 WI 157932
 Pg 11(3 to 4): Fuse F1 & F2 added.
 Pg 11(4): Description "Lubrication pump" was "Trabon".
 Prepared by, date: EM, 2017-09-20 Approved by, date: JN, 2017-09-29



Lab/Office:
 RMRO/PRIM

ROBOT CARRIER IRBT 4004/6004/7004
 TITLE PAGE

Status: APPROVED
 Plant: =
 Location: +
 Sublocation: +

Document no.	Rev. Ind	Page 2
3HAC043574-001	06	Next 3
		Total 23

*) SYSTEM CONFIGURATION

MOTOR No.	SMB NODE No.	UNIT
M7	7	IRBT SMB BOX A112

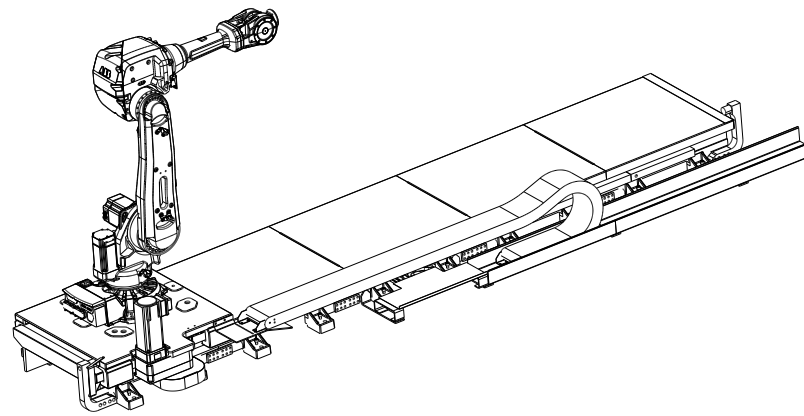

ON SINGLE CONTROLLER /
DRIVE MODULE

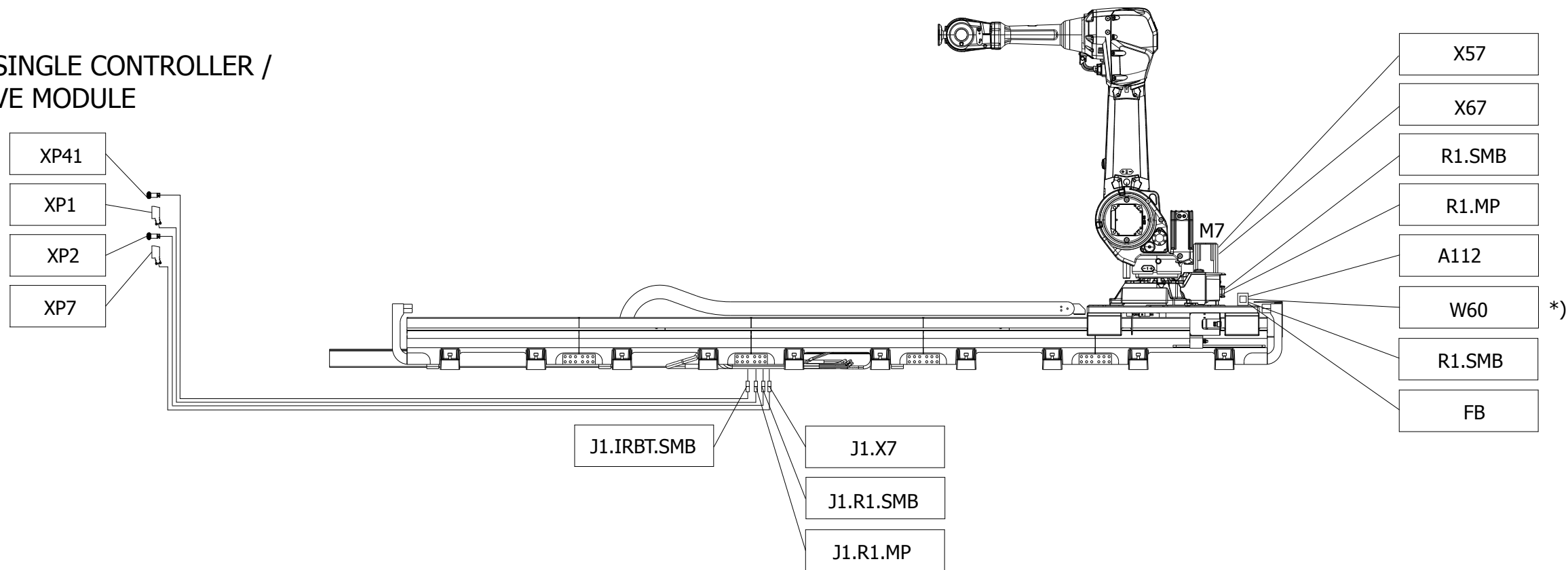

We reserve all rights in this document and in the information contained therein. Reproduction, use or disclosure to third parties without express authority is strictly forbidden. © Copyright 2003 ABB

Latest revision:
ECO 93258 WI 157932
Pg 11(3 to 4): Fuse F1 & F2 added.
Pg 11(4): Description "Lubrication pump" was "Trabon".
Prepared by, date: EM, 2017-09-20 Approved by, date: JN, 2017-09-29



Lab/Office:
RMRO/PRIM

ROBOT CARRIER IRBT 4004/6004/7004
BLOCK DIAGRAM
IRBT SMB BOX CONNECTION

Status:
APPROVED

Plant: =
Location: +
Sublocation: +

Document no.
3HAC043574-001

Rev. Ind
06
Page 4
Next 5
Total 23

*) SYSTEM CONFIGURATION

MOTOR No.	SMB NODE No.	UNIT
M7	7	IRB

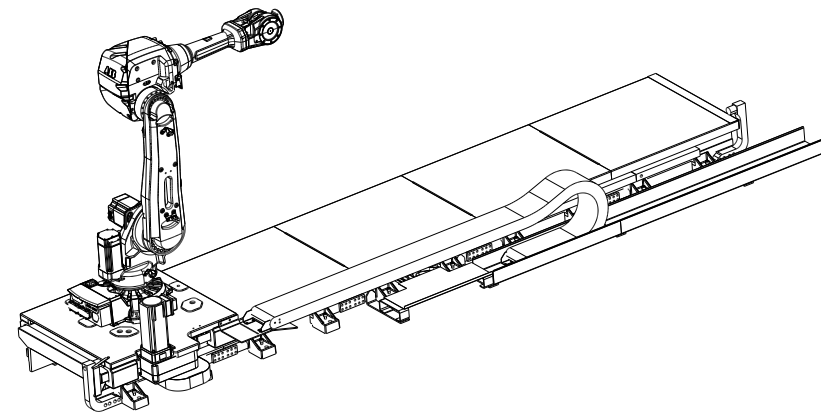

ON SINGLE CONTROLLER /
DRIVE MODULE

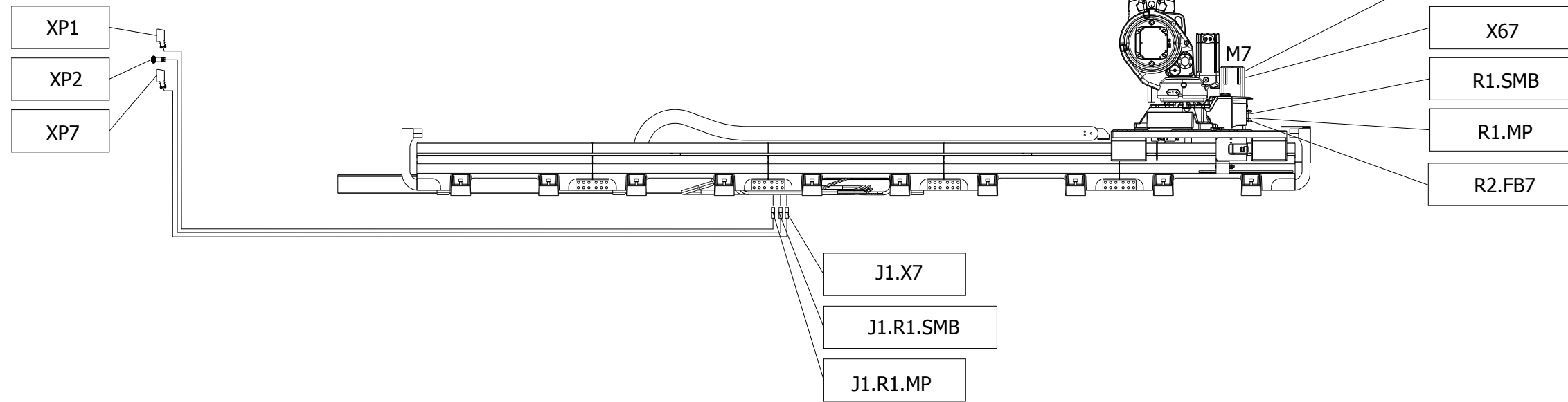

Latest revision:
ECO 93258 WI 157932
Pg 11(3 to 4): Fuse F1 & F2 added.
Pg 11(4): Description "Lubrication pump" was "Trabon".
Prepared by, date: EM, 2017-09-20 | Approved by, date: JN, 2017-09-29



ROBOT CARRIER IRBT 4004/6004/7004
BLOCK DIAGRAM
IRB SMB CONNECTION

Status: APPROVED
Plant: =
Location: +
Sublocation: +
Document no. 3HAC043574-001
Rev. Ind 06
Page 5
Next 6
Total 23

We reserve all rights in this document and in the information contained therein. Reproduction, use or disclosure to third parties without express authority is strictly forbidden. © Copyright 2003 ABB

SEE EL. DRAWINGS FOR THE
ROBOT CONTROL SYSTEM

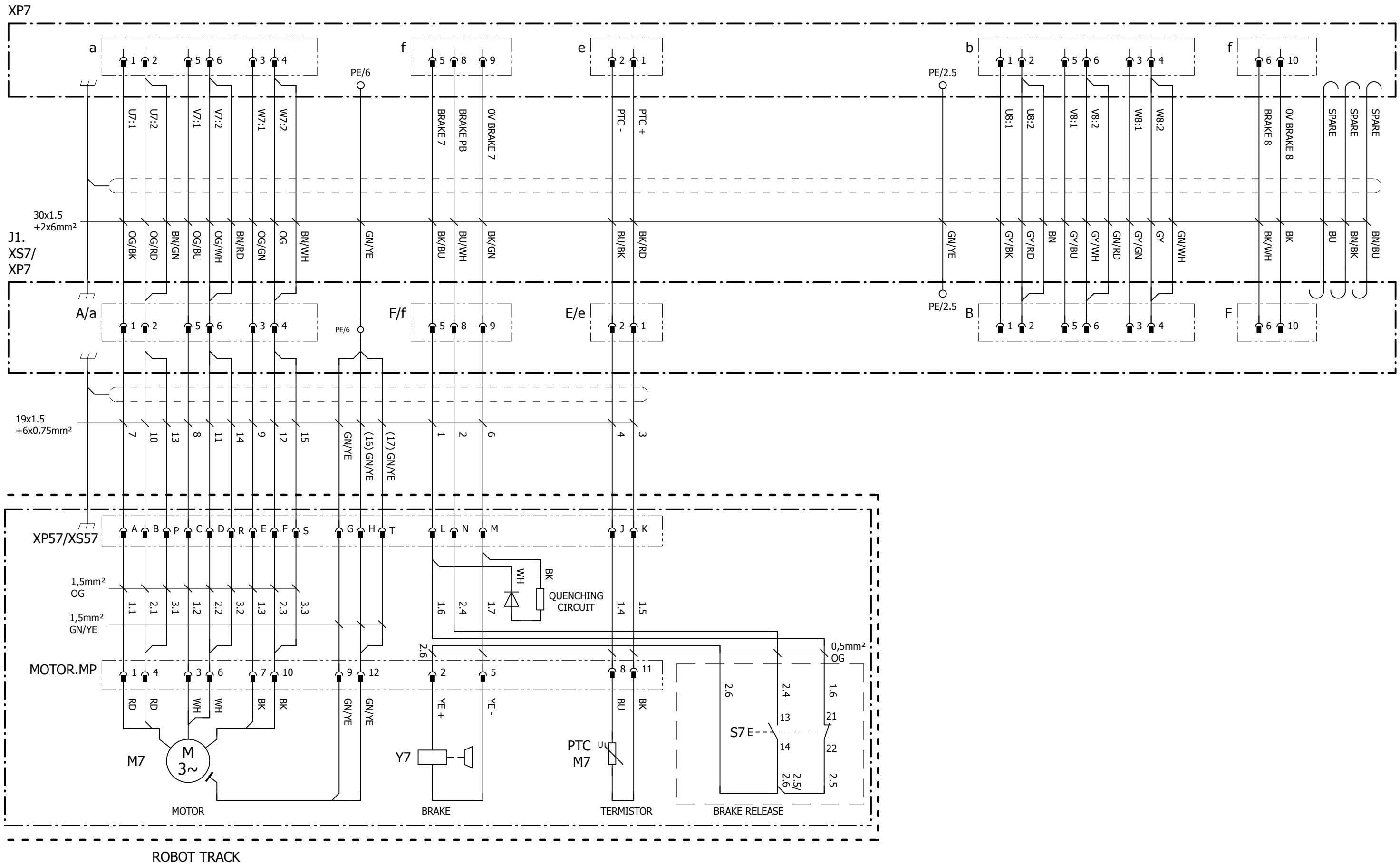

Latest revision:
ECO 93258 WI 157932
Pg 11(3 to 4): Fuse F1 & F2 added.
Pg 11(4): Description "Lubrication pump" was "Trabon".
Prepared by, date: EM, 2017-09-20
Approved by, date: JN, 2017-09-29



Lab/Office:
RMRO/PRIM

ROBOT CARRIER IRBT 4004/6004/7004
MOTOR IRBT, IRB2600/4400/4600/
6xx0/7600

Status:
APPROVED

Plant: =
Location: +
Sublocation: +

Document no. 3HAC043574-001 06
Rev. Ind Page 6
Next 7
Total 23

We reserve all rights in this document and in the information contained therein. Reproduction, use or disclosure to third parties without express authority is strictly forbidden. © Copyright 2003 ABB

SEE EL. DRAWINGS FOR THE
ROBOT CONTROL SYSTEM

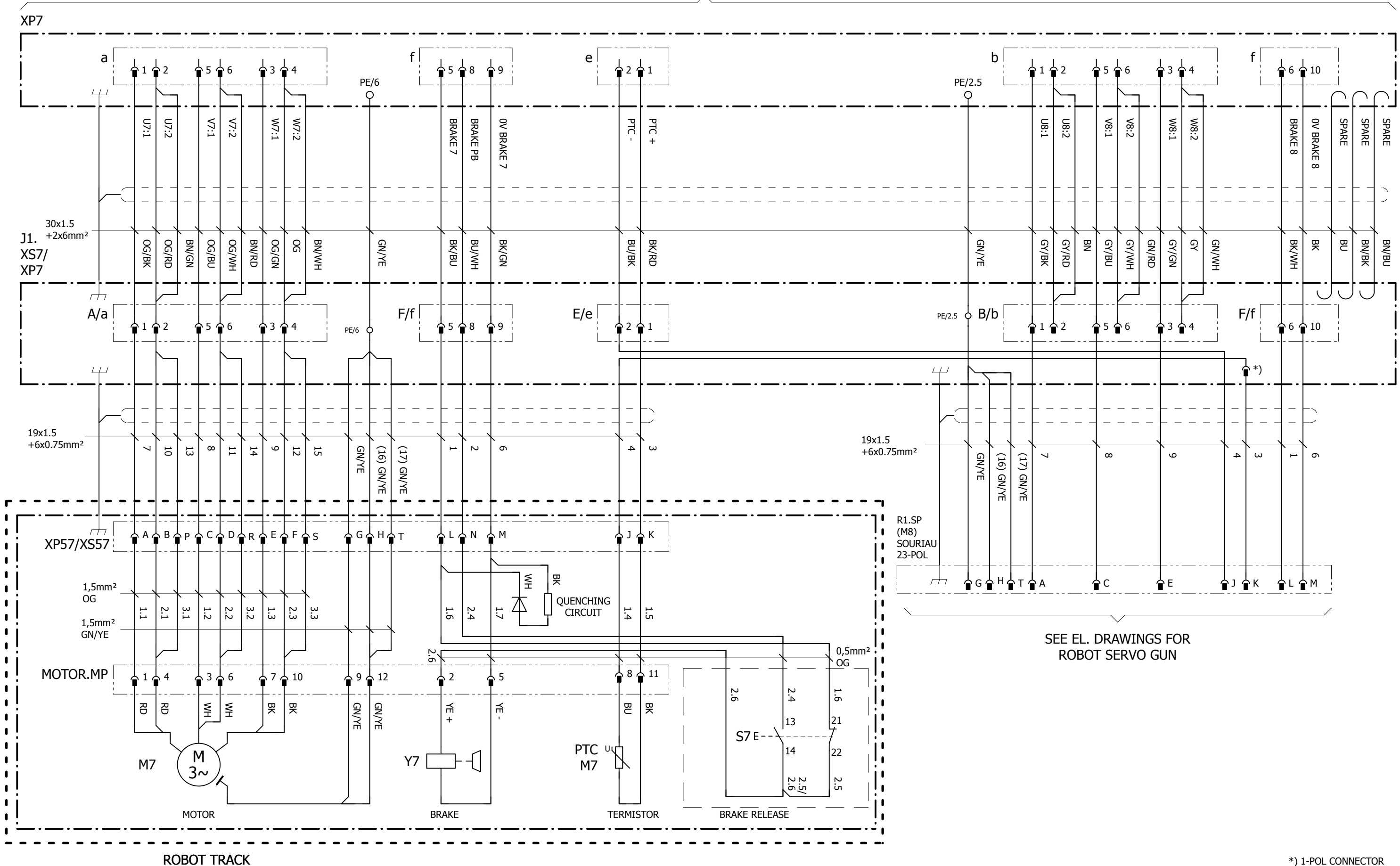

SEE EL. DRAWINGS FOR
ROBOT SERVO GUN

*) 1-POL CONNECTOR

Latest revision:
ECO 93258 WI 157932
Pg 11(3 to 4): Fuse F1 & F2 added.
Pg 11(4): Description "Lubrication pump" was "Trabon".
Prepared by, date: EM, 2017-09-20
Approved by, date: JN, 2017-09-29



Lab/Office:
RMRO/PRIM

ROBOT CARRIER IRBT 4004/6004/7004
MOTOR IRBT, OPTION SERVO GUN
IRB6xx0/IRB7600

Status:
APPROVED

Plant: =
Location: +
Sublocation: +

Document no.
3HAC043574-001

Rev. Ind
06
Page 7
Next 7.b
Total 23

SEE EL. DRAWINGS FOR THE
ROBOT CONTROL SYSTEM

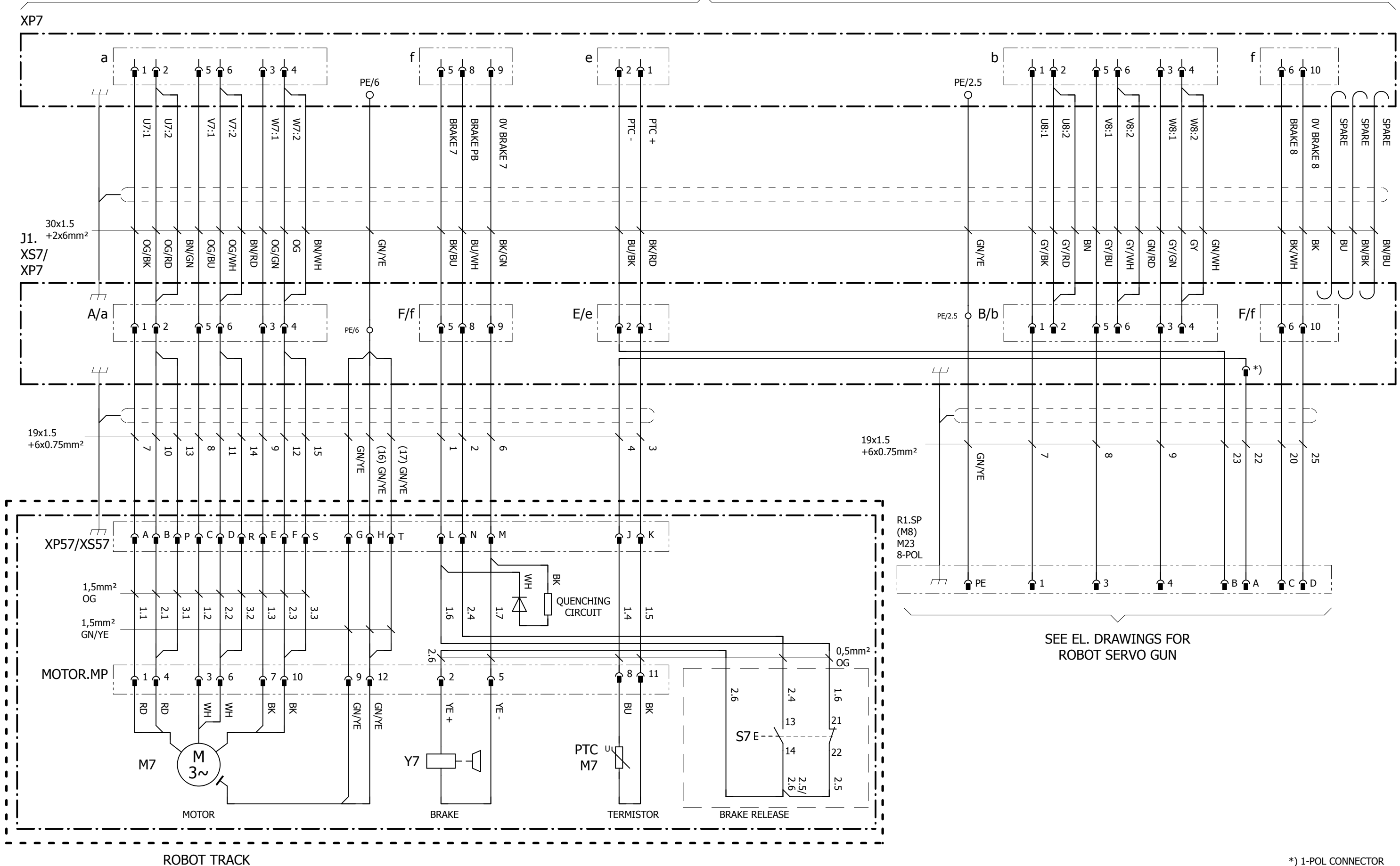

SEE EL. DRAWINGS FOR
ROBOT SERVO GUN

*) 1-POL CONNECTOR

Latest revision:
ECO 93258 WI 157932
Pg 11(3 to 4): Fuse F1 & F2 added.
Pg 11(4): Description "Lubrication pump" was "Trabon".
Prepared by, date: EM, 2017-09-20
Approved by, date: JN, 2017-09-29



Lab/Office:
RMRO/PRIM

ROBOT CARRIER IRBT 4004/6004/7004
MOTOR IRBT, OPTION SERVO GUN
IRB6xx0/IRB7600

Status:
APPROVED

Plant: =
Location: +
Sublocation: +

Document no.
3HAC043574-001 06
Rev. Ind
Page 7.b
Next 8
Total 23

We reserve all rights in this document and in the information contained therein. Reproduction, use or disclosure to third parties without express authority is strictly forbidden. © Copyright 2003 ABB

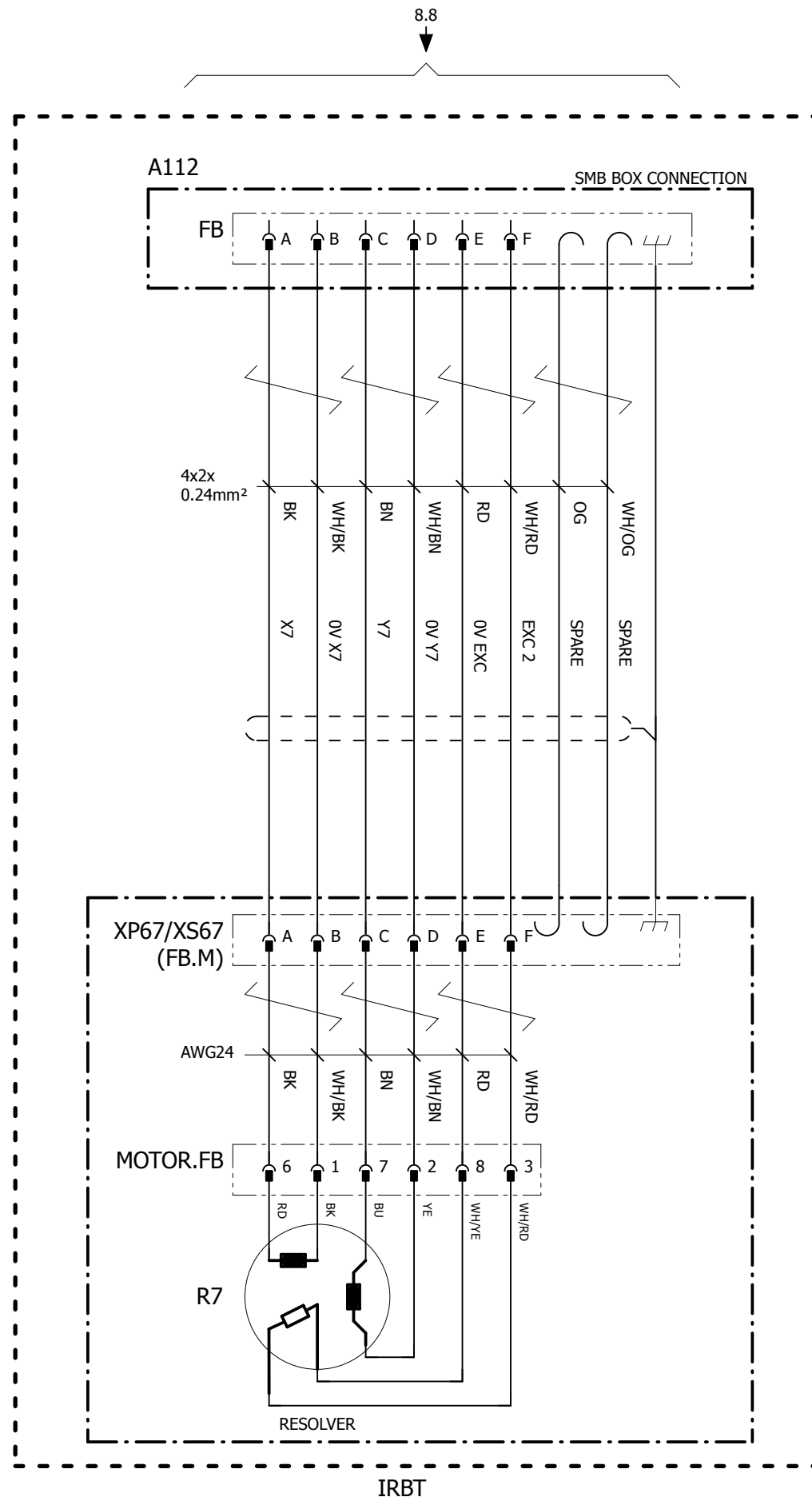

Latest revision:
 ECO 93258 WI 157932
 Pg 11(3 to 4): Fuse F1 & F2 added.
 Pg 11(4): Description "Lubrication pump" was "Trabon".
 Prepared by, date: EM, 2017-09-20 Approved by, date: JN, 2017-09-29



Lab/Office:
RMRO/PRIM

ROBOT CARRIER IRBT 4004/6004/7004
 RESOLVER MOTOR IRBT, SMB BOX
 CONN. IRB2600/4400/4600/6xx0/7600

Status:
APPROVED

Plant: =
 Location: +
 Sublocation: +

Document no.
3HAC043574-001

Rev. Ind
06

Page 9
Next 10
Total 23

We reserve all rights in this document and in the information contained therein. Reproduction, use or disclosure to third parties without express authority is strictly forbidden. © Copyright 2003 ABB

SEE EL.DWGS FOR THE IRB
MANIPULATOR

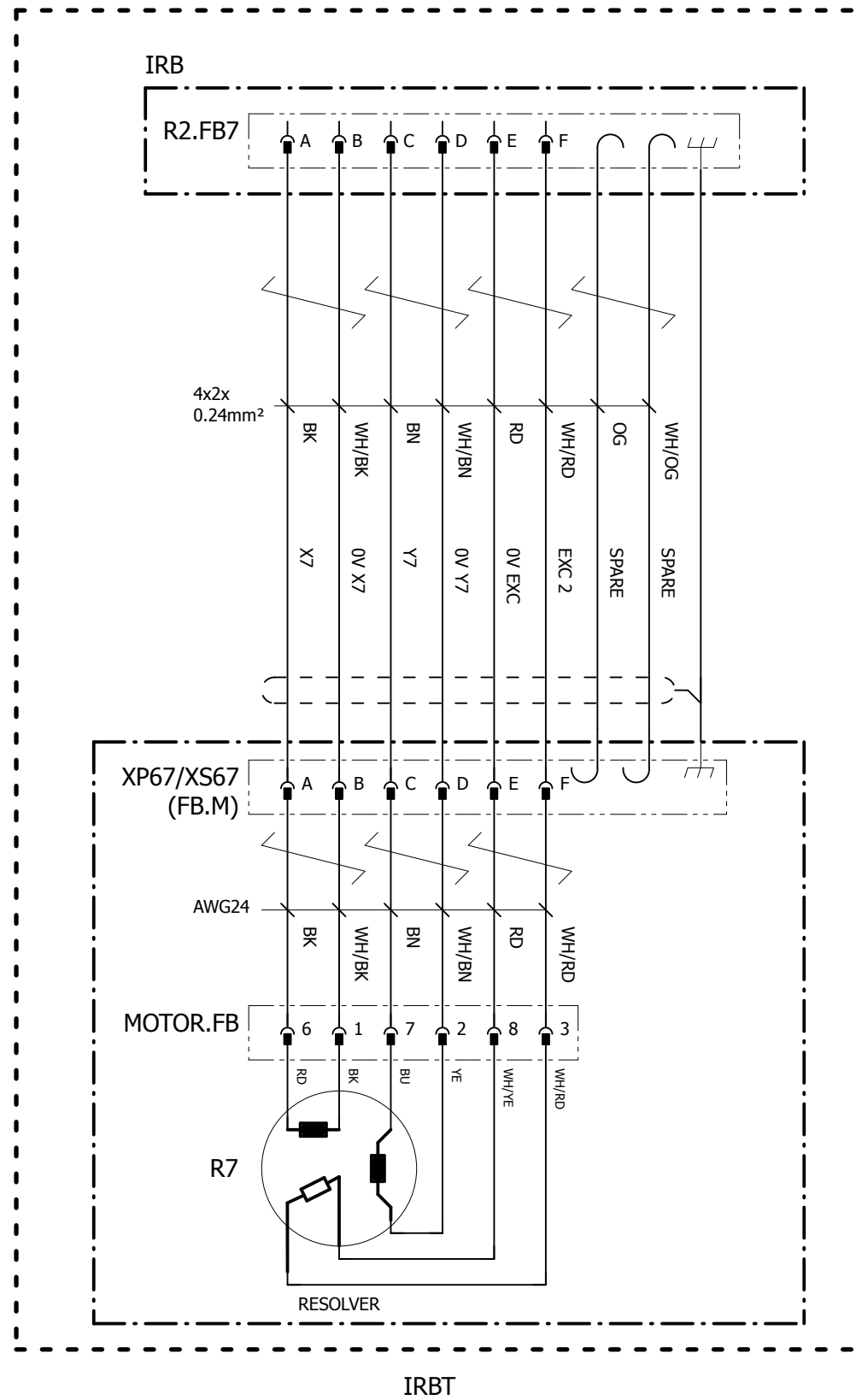

Latest revision:
ECO 93258 WI 157932
Pg 11(3 to 4): Fuse F1 & F2 added.
Pg 11(4): Description "Lubrication pump" was "Trabon".
Prepared by, date: EM, 2017-09-20 | Approved by, date: JN, 2017-09-29



Lab/Office:
RMRO/PRIM

ROBOT CARRIER IRBT 4004/6004/7004
RESOLVER MOTOR IRBT, IRB SMB
CONN. IRB2600/4400/4600/6xx0/7600

Status: APPROVED	Plant: = Location: + Sublocation: +
Document no. 3HAC043574-001	Rev. Ind 06
	Page 10 Next 11 Total 23

We reserve all rights in this document and in the information contained therein. Reproduction, use or disclosure to third parties without express authority is strictly forbidden. © Copyright 2003 ABB

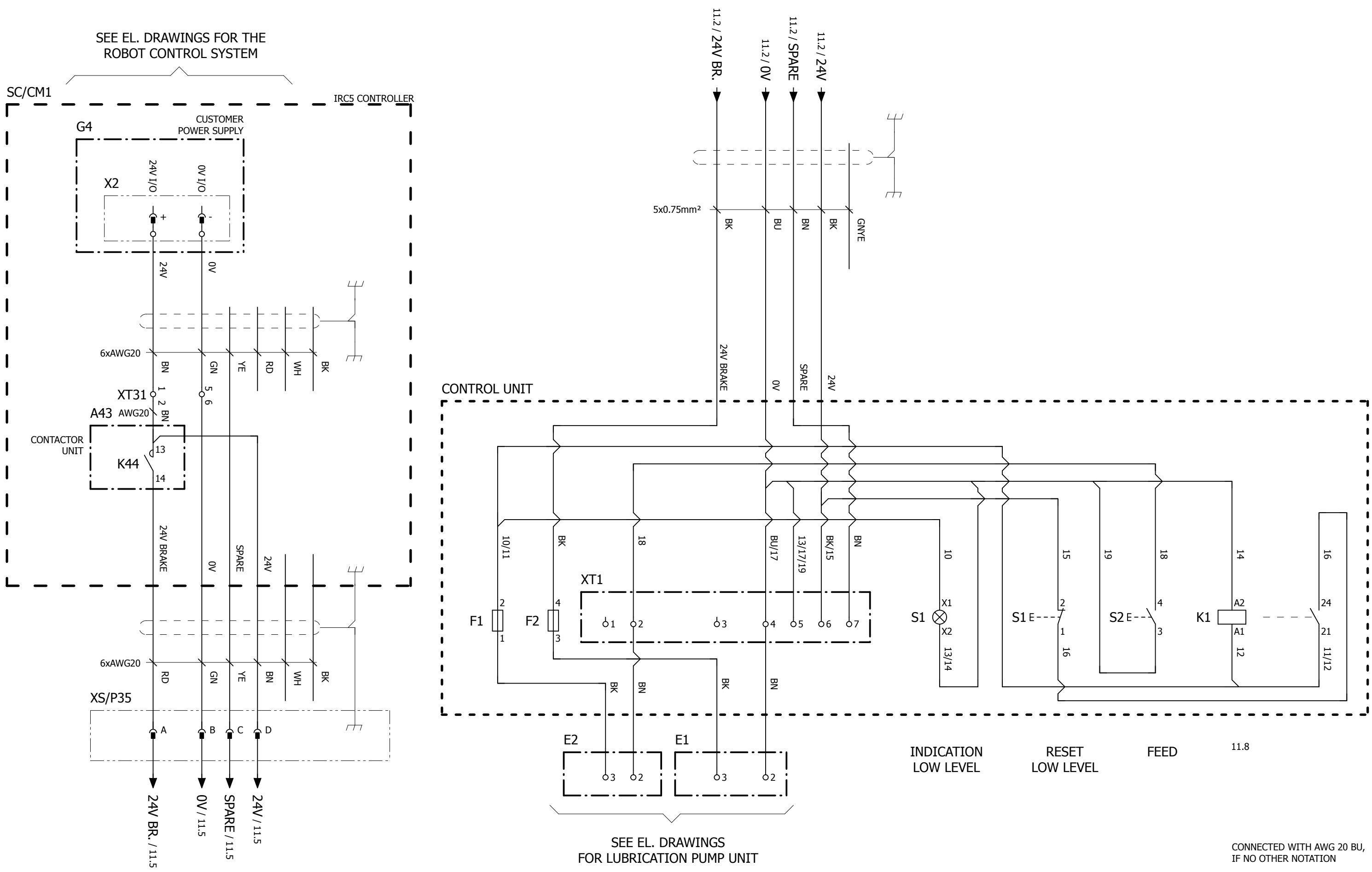

Latest revision:
 ECO 93258 WI 157932
 Pg 11(3 to 4): Fuse F1 & F2 added.
 Pg 11(4): Description "Lubrication pump" was "Trabon".
 Prepared by, date: EM, 2017-09-20 Approved by, date: JN, 2017-09-29



Lab/Office:
RMRO/PRIM

ROBOT CARRIER IRBT 4004/6004/7004
 OPTION LUBRICATION IRBT

Status:
APPROVED

Plant: =
 Location: +
 Sublocation: +

Document no.
3HAC043574-001

Rev. Ind **06**

Page 11
 Next 12
 Total 23

We reserve all rights in this document and in the information contained therein. Reproduction, use or disclosure to third parties without express authority is strictly forbidden. © Copyright 2003 ABB

SEE EL. DRAWINGS FOR THE
ROBOT CONTROL SYSTEM

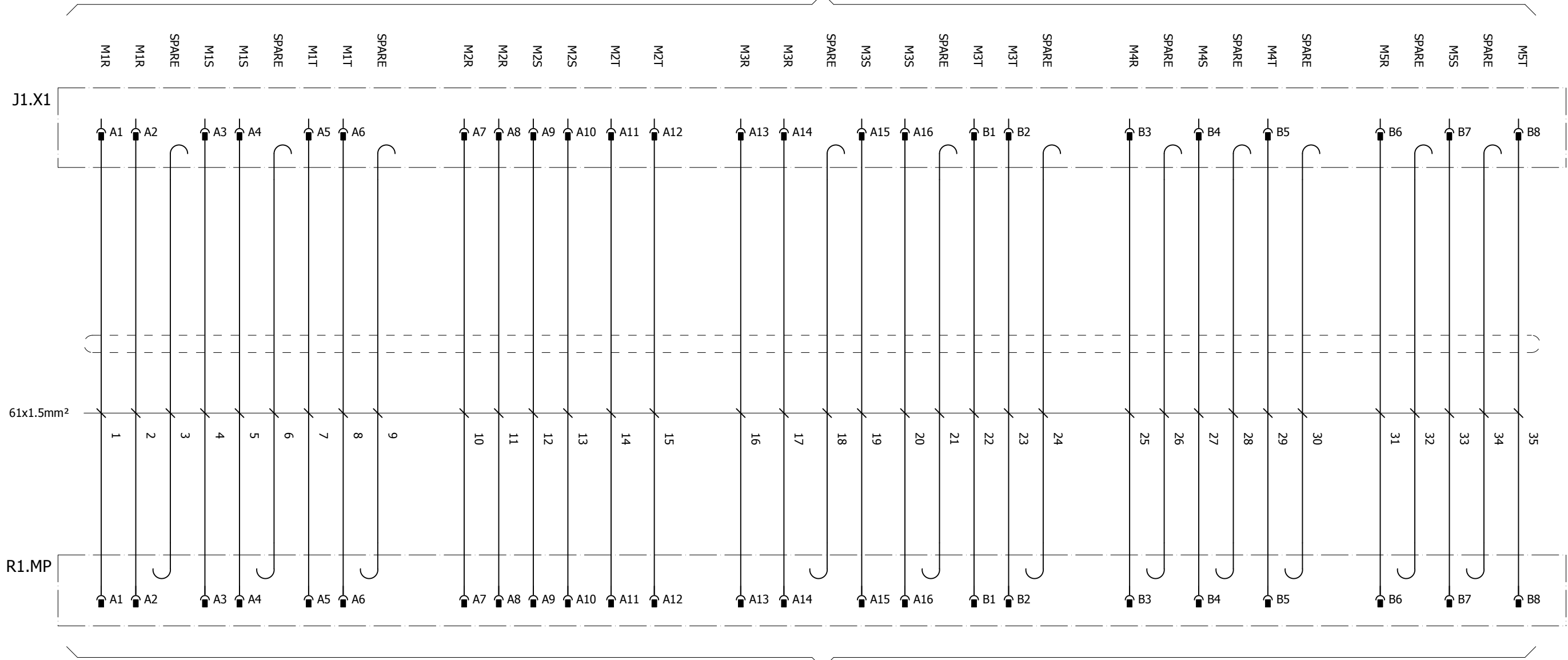

SEE EL. DRAWINGS FOR THE IRB MANIPULATOR

Latest revision:
ECO 93258 WI 157932
Pg 11(3 to 4): Fuse F1 & F2 added.
Pg 11(4): Description "Lubrication pump" was "Trabon".
Prepared by, date: EM, 2017-09-20 | Approved by, date: JN, 2017-09-29



Lab/Office:
RMRO/PRIM

ROBOT CARRIER IRBT 4004/6004/7004
MOTOR CABLE, IRB4400

Status:
APPROVED

Plant: =
Location: +
Sublocation: +

Document no.
3HAC043574-001

Rev. Ind
06
Page 12
Next 13
Total 23

We reserve all rights in this document and in the information contained therein. Reproduction, use or disclosure to third parties without express authority is strictly forbidden. © Copyright 2003 ABB

SEE EL. DRAWINGS FOR THE
ROBOT CONTROL SYSTEM

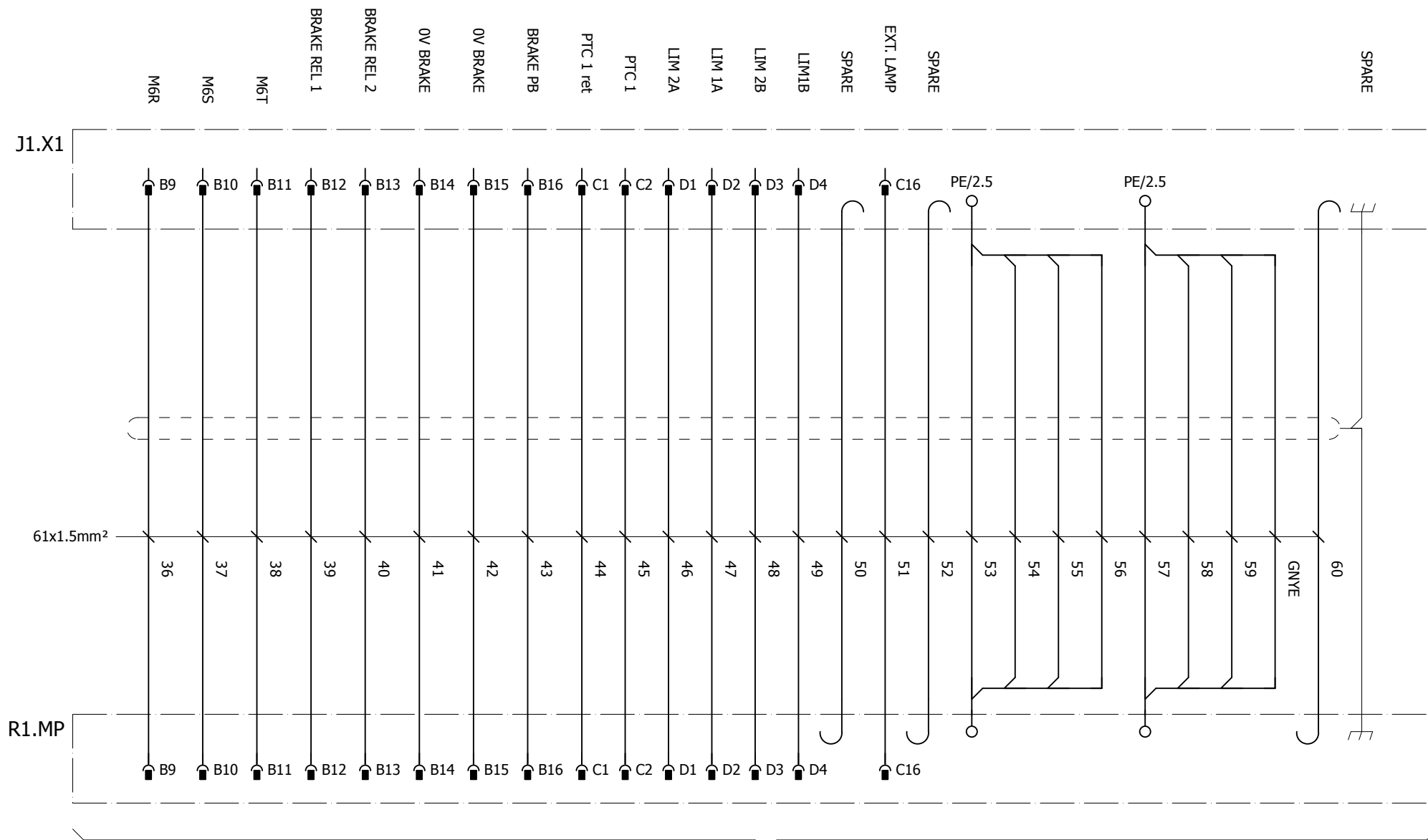

SEE EL. DRAWINGS FOR THE IRB MANIPULATOR

Latest revision:
ECO 93258 WI 157932
Pg 11(3 to 4): Fuse F1 & F2 added.
Pg 11(4): Description "Lubrication pump" was "Trabon".
Prepared by, date: EM, 2017-09-20 | Approved by, date: JN, 2017-09-29



Lab/Office:
RMRO/PRIM

ROBOT CARRIER IRBT 4004/6004/7004
MOTOR CABLE, IRB4400

Status:
APPROVED

Plant: =
Location: +
Sublocation: +

Document no.
3HAC043574-001

Rev. Ind
06
Page 13
Next 14
Total 23

We reserve all rights in this document and in the information contained therein. Reproduction, use or disclosure to third parties without express authority is strictly forbidden. © Copyright 2003 ABB

SEE EL. DRAWINGS FOR THE
ROBOT CONTROL SYSTEM

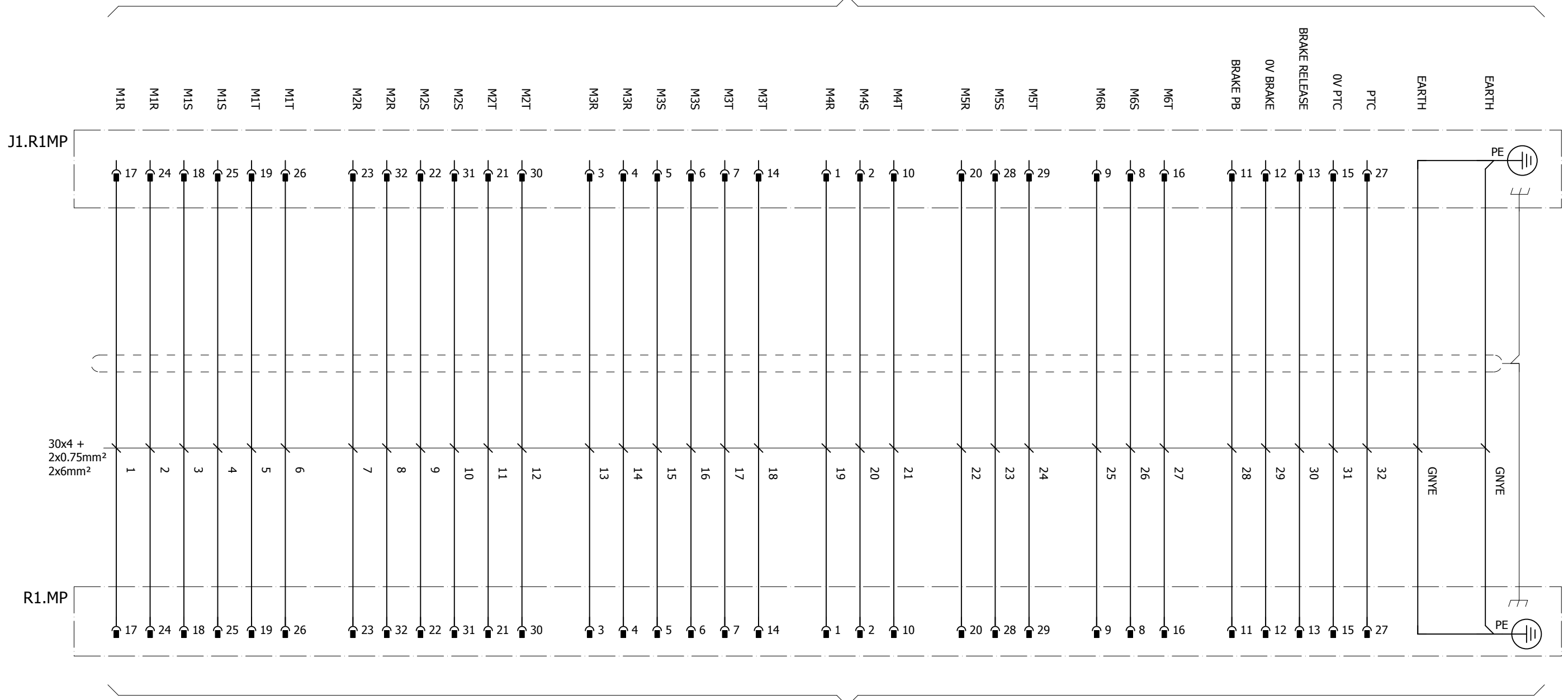

SEE EL. DRAWINGS FOR THE
IRB MANIPULATOR

Latest revision:
ECO 93258 WI 157932
Pg 11(3 to 4): Fuse F1 & F2 added.
Pg 11(4): Description "Lubrication pump" was "Trabon".
Prepared by, date: EM, 2017-09-20 Approved by, date: JN, 2017-09-29



Lab/Office:
RMRO/PRIM

ROBOT CARRIER IRBT 4004/6004/7004
MOTOR CABLE, IRB2600/4600/6xx0/
7600

Status:
APPROVED

Plant: =
Location: +
Sublocation: +

Document no.
3HAC043574-001

Rev. Ind
06

Page 14
Next 15
Total 23

We reserve all rights in this document and in the information contained therein. Reproduction, use or disclosure to third parties without express authority is strictly forbidden. © Copyright 2003 ABB

SEE EL. DRAWINGS FOR THE
ROBOT CONTROL SYSTEM

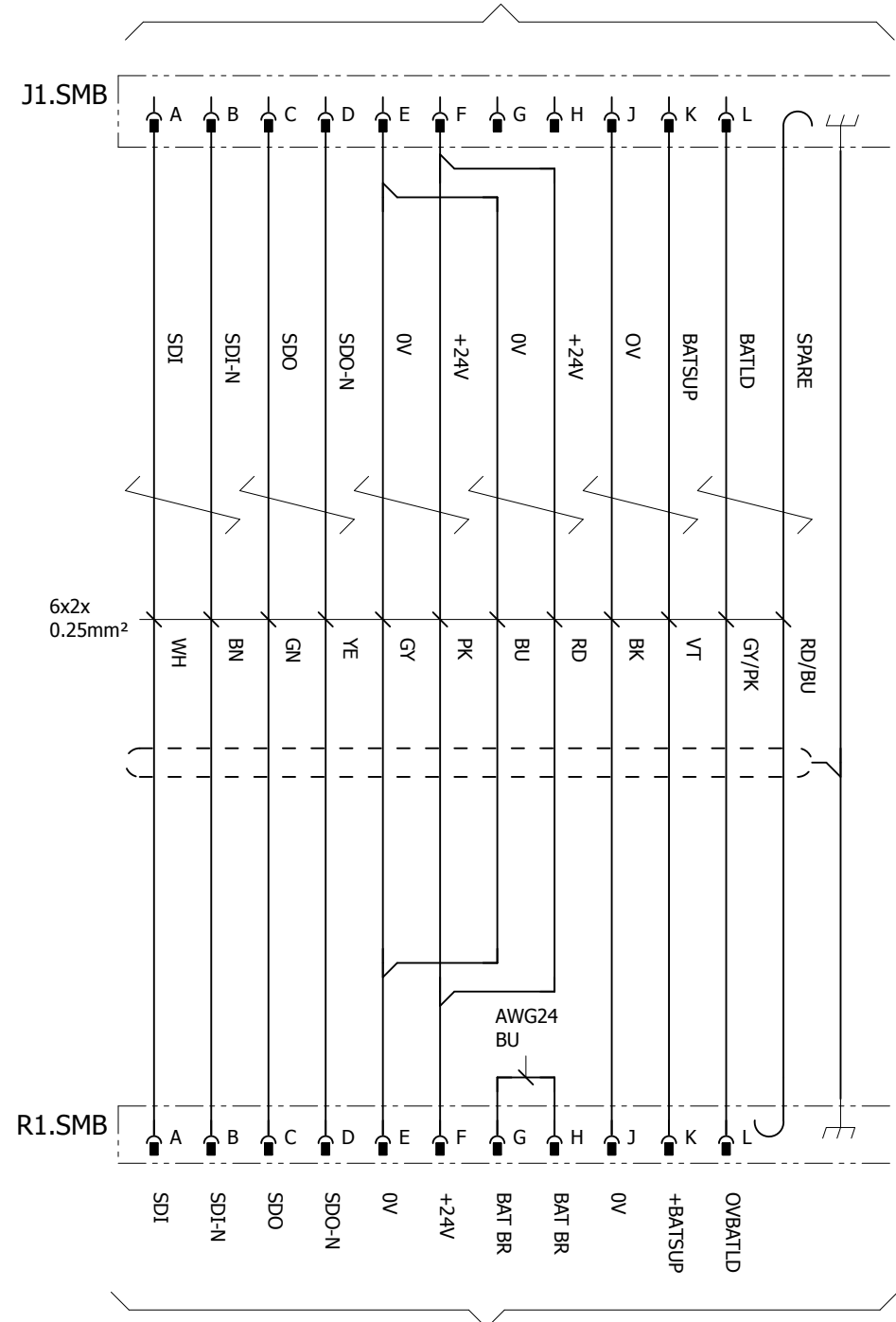

SEE EL.DWGS FOR THE
IRB MANIPULATOR

Latest revision:
ECO 93258 WI 157932
Pg 11(3 to 4): Fuse F1 & F2 added.
Pg 11(4): Description "Lubrication pump" was "Trabon".
Prepared by, date: EM, 2017-09-20 Approved by, date: JN, 2017-09-29



Lab/Office:
RMRO/PRIM

ROBOT CARRIER IRBT 4004/6004/7004
RESOLVER CABLE, IRB2600/4400/4600/
6xx0/7600

Status:
APPROVED

Plant: =
Location: +
Sublocation: +

Document no. **3HAC043574-001** Rev. Ind **06**
Page 15
Next 16
Total 23

We reserve all rights in this document and in the information contained therein. Reproduction, use or disclosure to third parties without express authority is strictly forbidden. © Copyright 2003 ABB

SEE EL. DRAWINGS FOR THE
ROBOT CONTROL SYSTEM

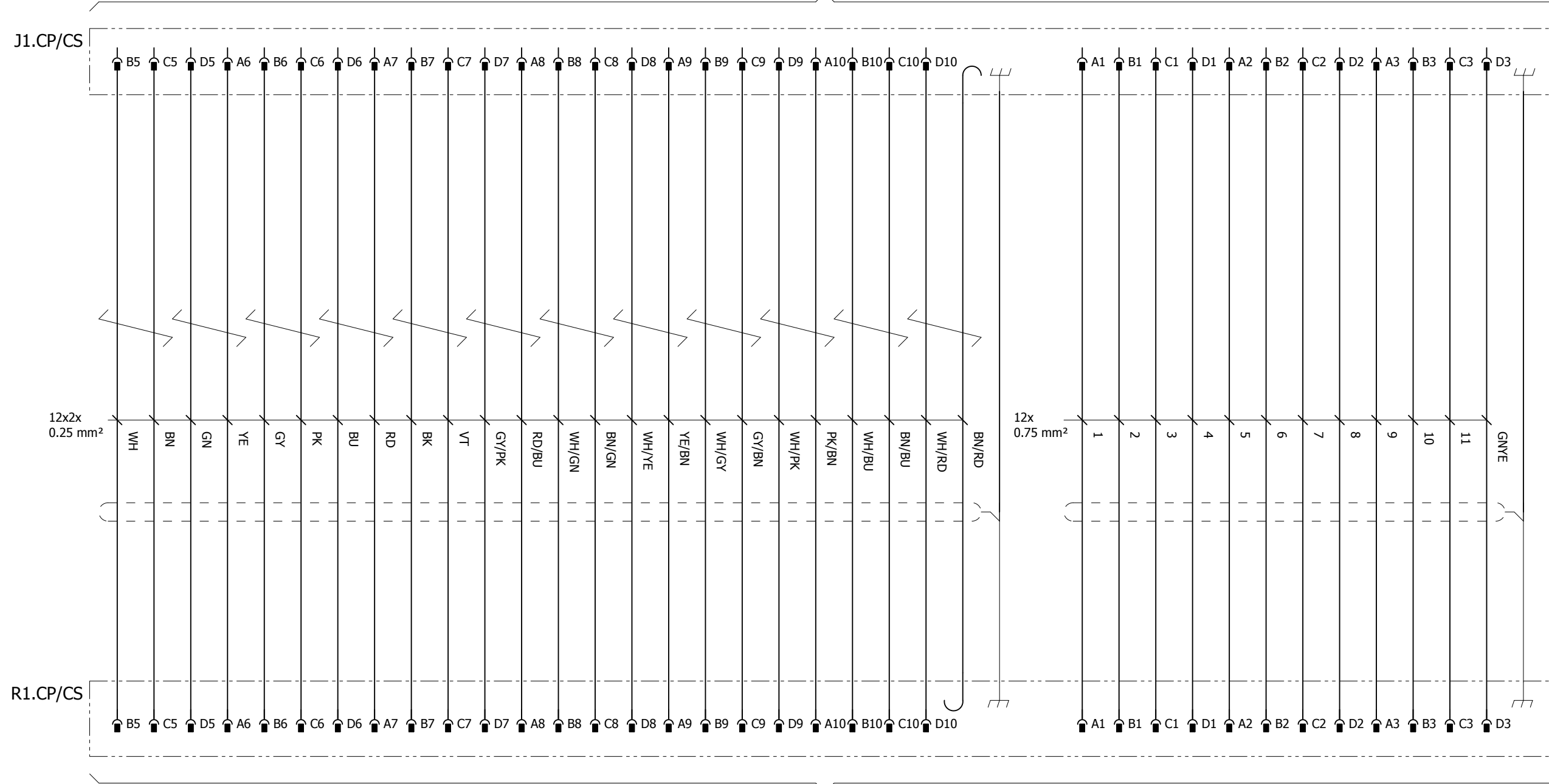

SEE EL. DRAWINGS FOR THE
IRB MANIPULATOR

Latest revision:
ECO 93258 WI 157932
Pg 11(3 to 4): Fuse F1 & F2 added.
Pg 11(4): Description "Lubrication pump" was "Trabon".
Prepared by, date: EM, 2017-09-20 | Approved by, date: JN, 2017-09-29



Lab/Office:
RMRO/PRIM

ROBOT CARRIER IRBT 4004/6004/7004
OPTION CUSTOMER POWER/SIGNAL,
IRB4400

Status: APPROVED	Plant: = Location: + Sublocation: +
Document no. 3HAC043574-001	Rev. Ind 06
	Page 16 Next 17 Total 23

We reserve all rights in this document and in the information contained therein. Reproduction, use or disclosure to third parties without express authority is strictly forbidden. © Copyright 2003 ABB

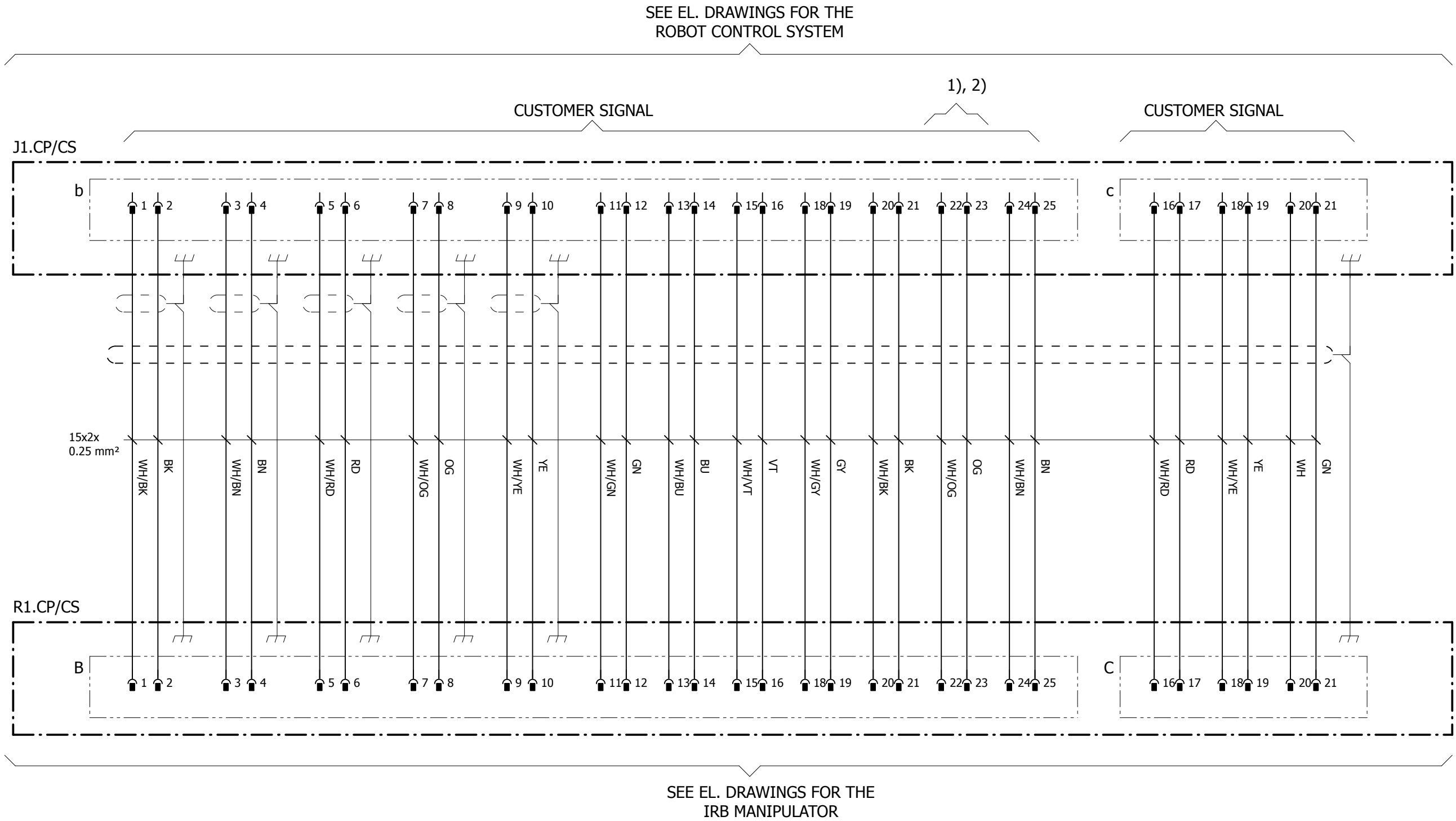

- 1) Part OG, WH/OG not connected to b/B.22,23 when Opt. DeviceNet, see sh. 18.
- 2) Part WH/OG not connected to b/B.22 when Opt. Interbus, see sh. 19.

Latest revision:
ECO 93258 WI 157932
Pg 11(3 to 4): Fuse F1 & F2 added.
Pg 11(4): Description "Lubrication pump" was "Trabon".
Prepared by, date: EM, 2017-09-20 Approved by, date: JN, 2017-09-29



Lab/Office:
RMRO/PRIM

ROBOT CARRIER IRBT 4004/6004/7004
OPTION CUSTOMER POWER/SIGNAL,
IRB2600/4600/6xx0/7600

Status:
APPROVED

Plant: =
Location: +
Sublocation: +

Document no.
3HAC043574-001

Rev. Ind	Page 17
06	Next 18
	Total 23

SEE EL. DRAWINGS FOR THE
ROBOT CONTROL SYSTEM

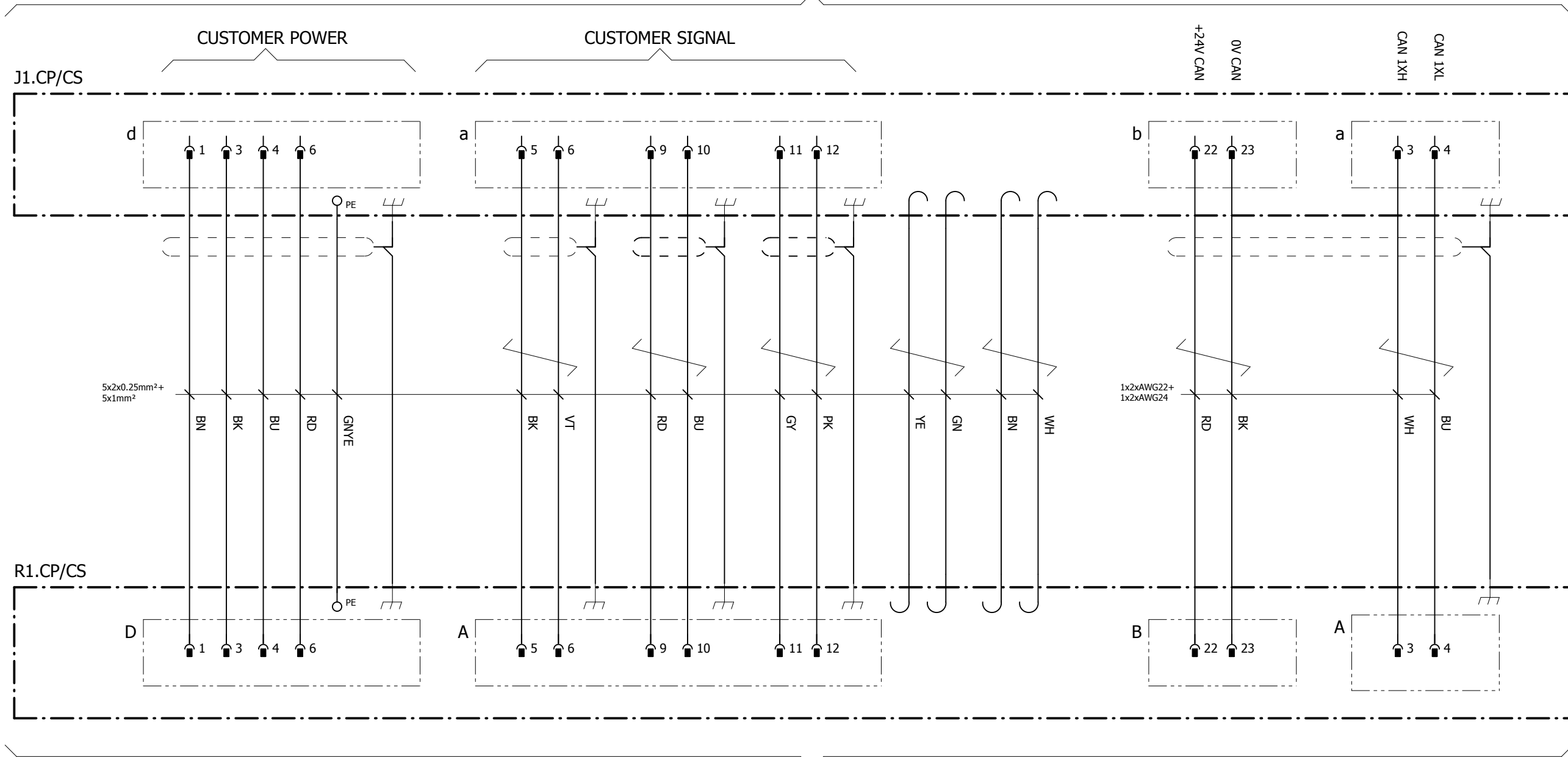

SEE EL. DRAWINGS FOR THE
IRB MANIPULATOR

We reserve all rights in this document and in the information contained therein. Reproduction, use or disclosure to third parties without express authority is strictly forbidden. © Copyright 2003 ABB

Latest revision:
ECO 93258 WI 157932
Pg 11(3 to 4): Fuse F1 & F2 added.
Pg 11(4): Description "Lubrication pump" was "Trabon".
Prepared by, date: EM, 2017-09-20 | Approved by, date: JN, 2017-09-29



Lab/Office:
RMRO/PRIM

ROBOT CARRIER IRBT 4004/6004/7004
OPTION CUSTOMER POWER/SIGNAL
DEVICENET, IRB2600/4600/6xx0/7600

Status:
APPROVED

Plant: =
Location: +
Sublocation: +

Document no.
3HAC043574-001

Rev. Ind
06
Page 18
Next 19
Total 23

SEE EL. DRAWINGS FOR THE
ROBOT CONTROL SYSTEM

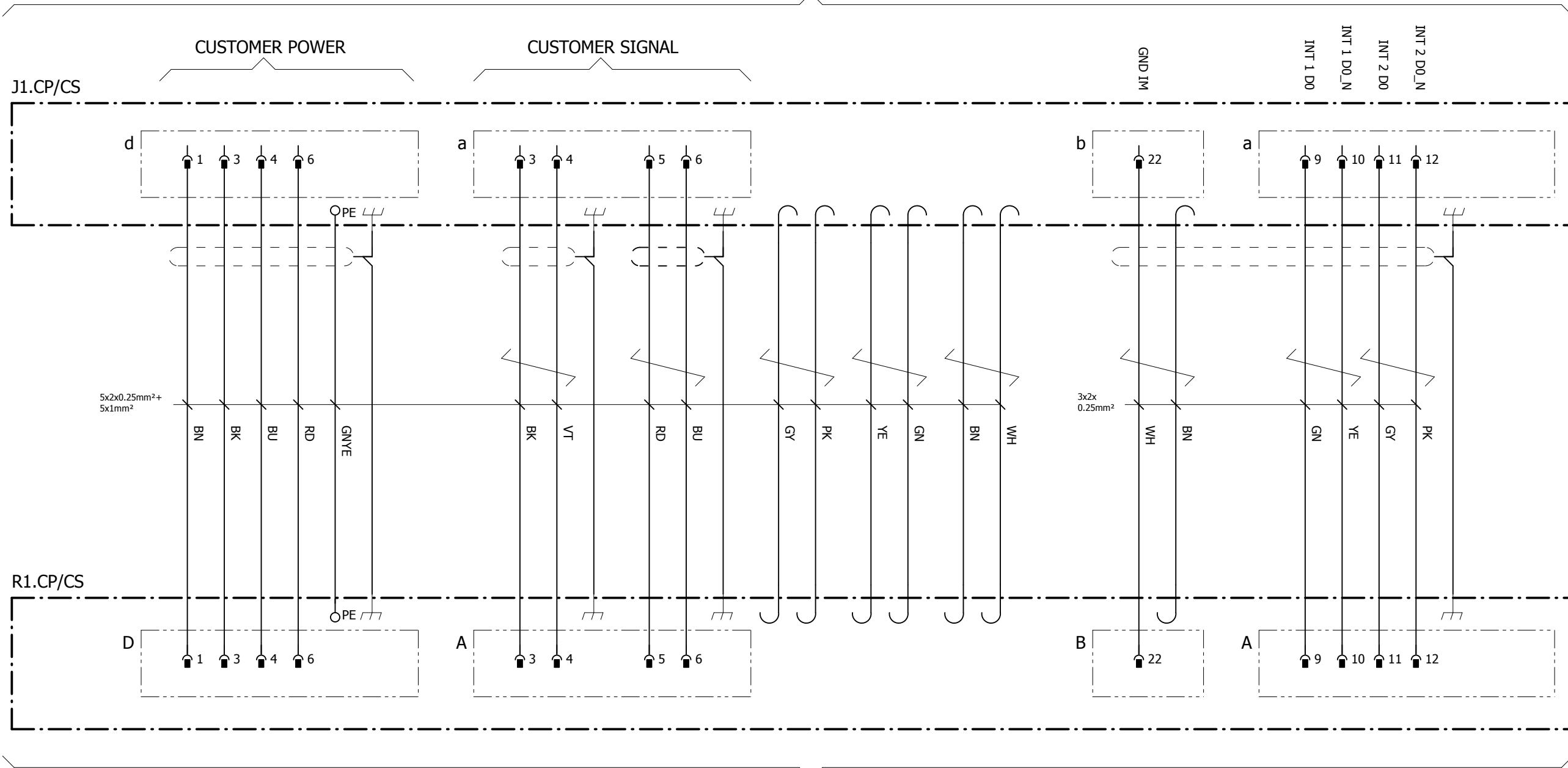

SEE EL. DRAWINGS FOR THE
IRB MANIPULATOR

We reserve all rights in this document and in the information contained therein. Reproduction, use or disclosure to third parties without express authority is strictly forbidden. © Copyright 2003 ABB

Latest revision:
ECO 93258 WI 157932
Pg 11(3 to 4): Fuse F1 & F2 added.
Pg 11(4): Description "Lubrication pump" was "Trabon".
Prepared by, date: EM, 2017-09-20 | Approved by, date: JN, 2017-09-29



Lab/Office:
RMRO/PRIM

ROBOT CARRIER IRBT 4004/6004/7004
OPTION CUSTOMER POWER/SIGNAL
INTERBUS, IRB 6xx0/7600

Status:
APPROVED

Plant: =
Location: +
Sublocation: +

Document no.
3HAC043574-001

Rev. Ind
06
Page 19
Next 20
Total 23

SEE EL. DRAWINGS FOR THE
ROBOT CONTROL SYSTEM

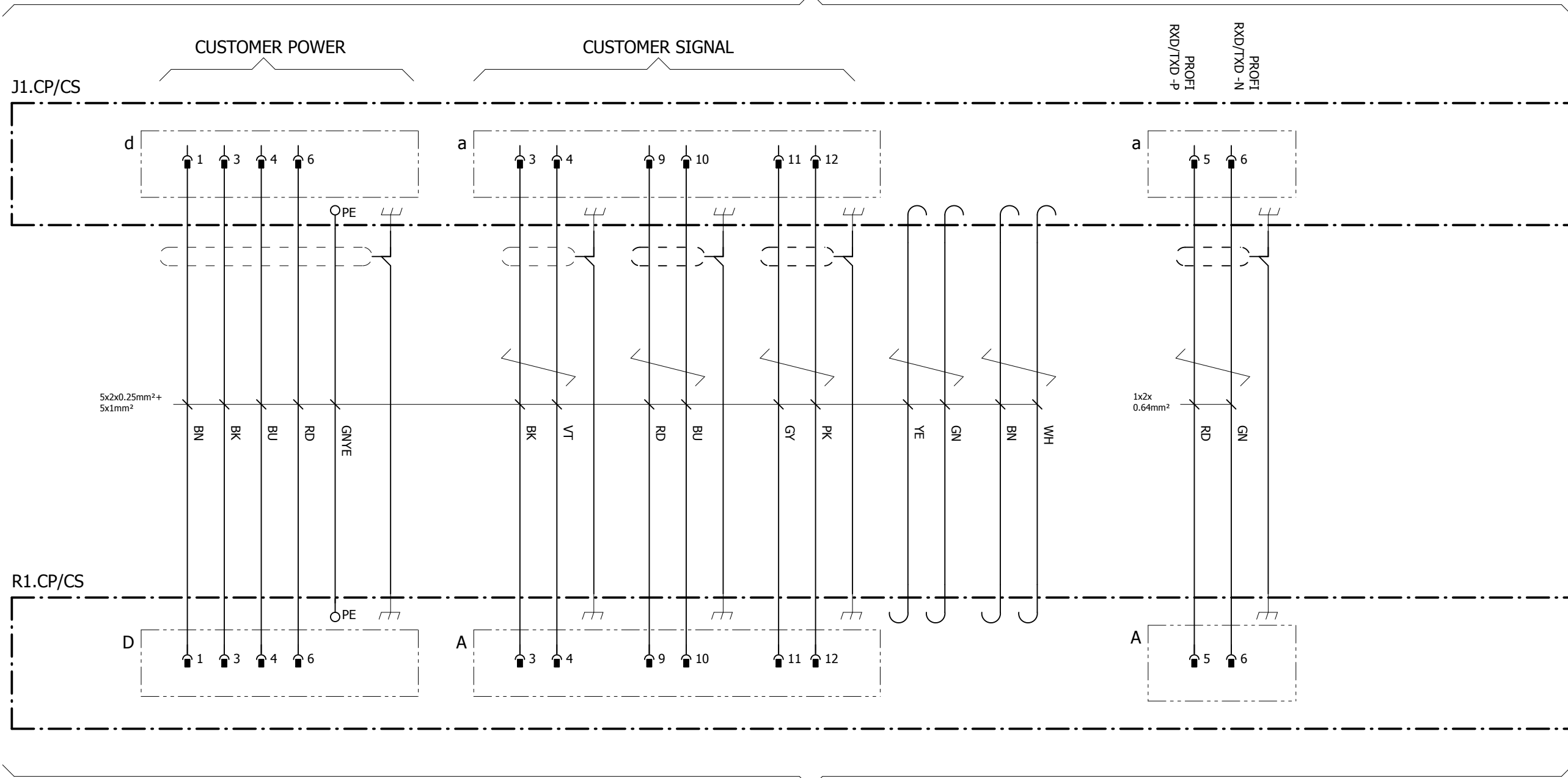

SEE EL. DRAWINGS FOR THE
IRB MANIPULATOR

We reserve all rights in this document and in the information contained therein. Reproduction, use or disclosure to third parties without express authority is strictly forbidden. © Copyright 2003 ABB

Latest revision:
ECO 93258 WI 157932
Pg 11(3 to 4): Fuse F1 & F2 added.
Pg 11(4): Description "Lubrication pump" was "Trabon".
Prepared by, date: EM, 2017-09-20 | Approved by, date: JN, 2017-09-29



Lab/Office:
RMRO/PRIM

ROBOT CARRIER IRBT 4004/6004/7004
OPTION CUSTOMER POWER/SIGNAL
PROFIBUS, IRB 6xx0/7600

Status:
APPROVED

Plant: =
Location: +
Sublocation: +

Document no.
3HAC043574-001

Rev. Ind
06
Page 20
Next 21
Total 23

We reserve all rights in this document and in the information contained therein. Reproduction, use or disclosure to third parties without express authority is strictly forbidden. © Copyright 2003 ABB

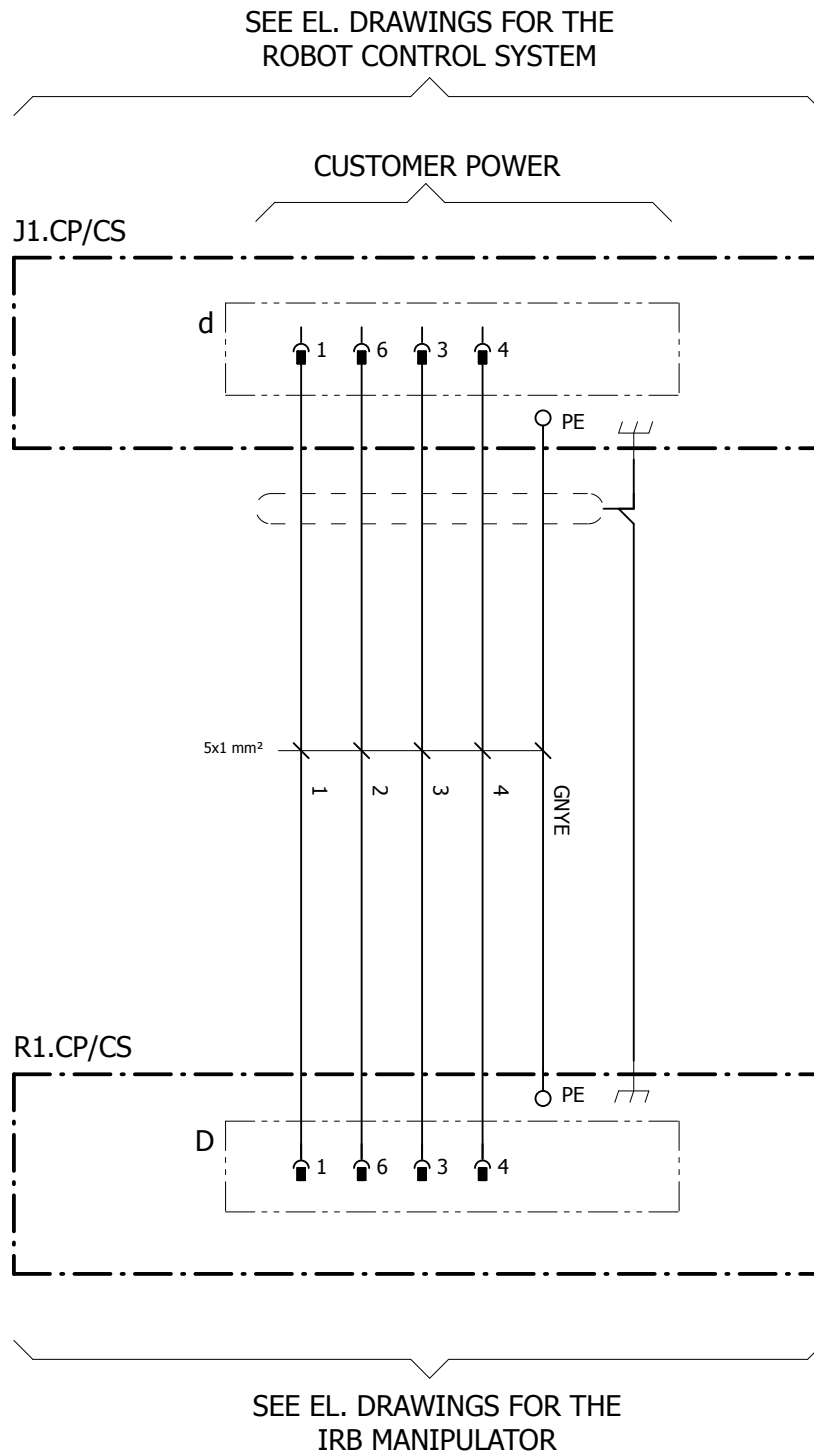

Latest revision:
ECO 93258 WI 157932
Pg 11(3 to 4): Fuse F1 & F2 added.
Pg 11(4): Description "Lubrication pump" was "Trabon".
Prepared by, date: EM, 2017-09-20 | Approved by, date: JN, 2017-09-29



Lab/Office:
RMRO/PRIM

ROBOT CARRIER IRBT 4004/6004/7004
OPTION CUSTOMER POWER/SIGNAL
PARALLEL, IRB2600/4600/6xx0/7600

Status:
APPROVED

Plant: =
Location: +
Sublocation: +

Document no.
3HAC043574-001

Rev. Ind
06

Page 21
Next 22
Total 23

SEE EL. DRAWINGS FOR THE
ROBOT CONTROL SYSTEM

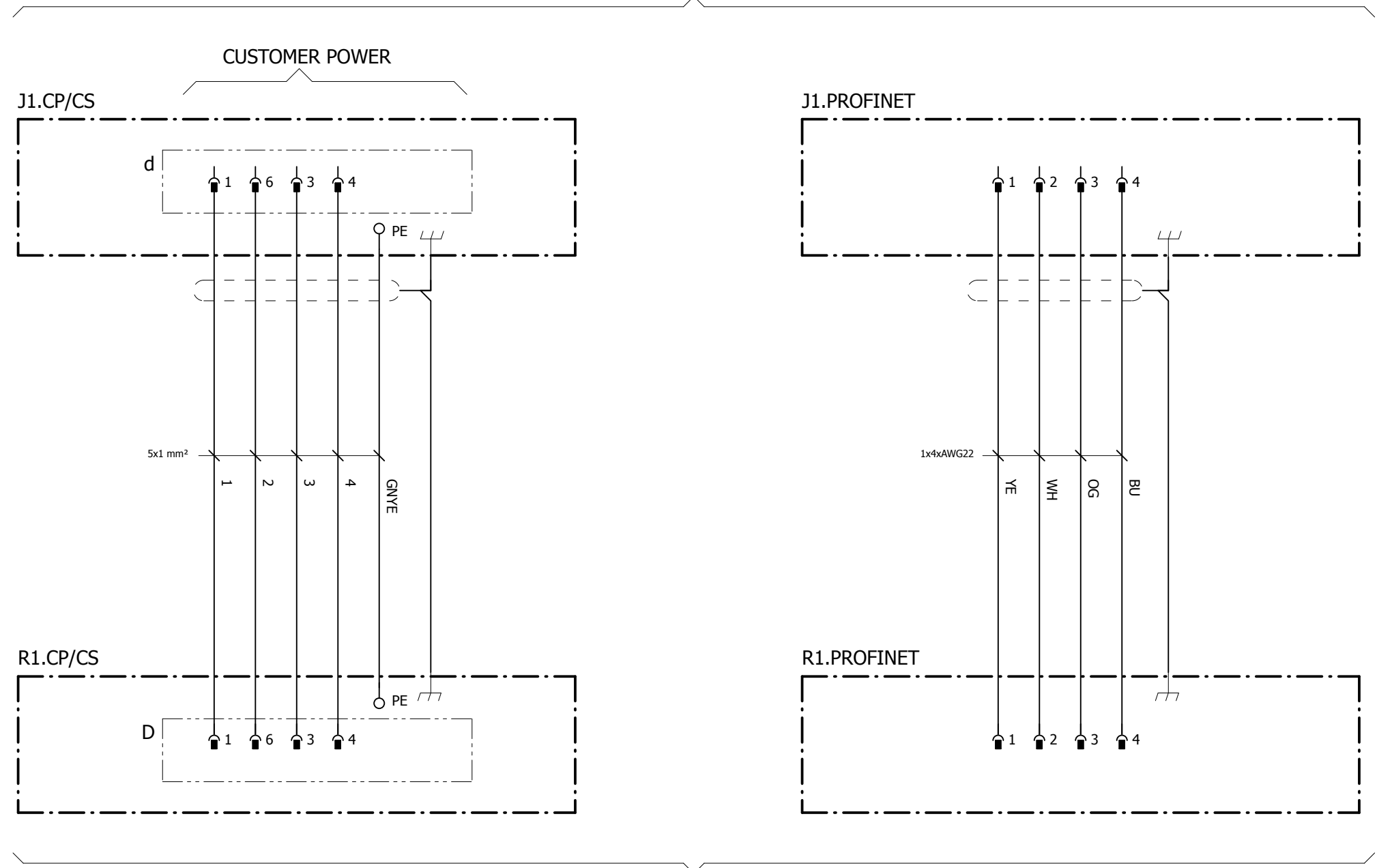

SEE EL. DRAWINGS FOR THE
IRB MANIPULATOR

We reserve all rights in this document and in the information contained therein. Reproduction, use or disclosure to third parties without express authority is strictly forbidden. © Copyright 2003 ABB

Latest revision:
ECO 93258 WI 157932
Pg 11(3 to 4): Fuse F1 & F2 added.
Pg 11(4): Description "Lubrication pump" was "Trabon".
Prepared by, date: EM, 2017-09-20 | Approved by, date: JN, 2017-09-29



Lab/Office:
RMRO/PRIM

ROBOT CARRIER IRBT 4004/6004/7004
OPTION CUSTOMER POWER/SIGNAL
PROFINET, IRB2600/4600/6xx0/7600

Status:
APPROVED

Plant: =
Location: +
Sublocation: +

Document no.
3HAC043574-001

Rev. Ind
06
Page 22
Next
Total 23